



Designation: D6251/D6251M – 19

Standard Specification for Wood-Cleated Panelboard Shipping Boxes¹

This standard is issued under the fixed designation D6251/D6251M; the number immediately following the designation indicates the year of original adoption or, in the case of revision, the year of last revision. A number in parentheses indicates the year of last reapproval. A superscript epsilon (ϵ) indicates an editorial change since the last revision or reapproval.

1. Scope*

1.1 This specification covers the fabrication and closure of empty and full wood-cleated, hereafter referred to as wood-cleated, panelboard boxes. These boxes are intended for use as containers for domestic and overseas shipment of general materials and supplies, not exceeding 1000 lb [454 kg] depending on box type (see 10.1).

1.2 Wood-cleated panelboard shipping box performance is dependent on its fabricated components and subsequent assembly; therefore, a variety of types, classes, styles, and treatments reflecting varied performance are specified. This specification, however, does not cover wood-cleated panelboard box performance under all atmospheric, handling, shipping, and storage conditions.

1.3 If the use of other construction methods or techniques is acceptable and permitted (see 5.1.17), the resulting packaging systems shall be of equal or better performance than would result from the use of these specified materials and procedures. The appropriate distribution cycle, specified in Practice D4169, can be used to develop comparative procedures and criteria.

1.4 The values stated in either inch-pound units or SI units are to be regarded separately as standard. Within the text, the SI units are shown in brackets. The values stated in each system are not exact equivalents; therefore, each system must be used independently of the other. Combining values from the two systems may result in nonconformance with the standard. See IEEE/ASTM SI 10 for conversion of units.

1.5 *This standard does not purport to address all of the safety concerns, if any, associated with its use. It is the responsibility of the user of this standard to establish appropriate safety, health, and environmental practices and determine the applicability of regulatory limitations prior to use.*

1.6 *This international standard was developed in accordance with internationally recognized principles on standardization established in the Decision on Principles for the Development of International Standards, Guides and Recom-*

¹ This specification is under the jurisdiction of ASTM Committee D10 on Packaging and is the direct responsibility of Subcommittee D10.12 on Shipping Containers, Crates, Pallets, Skids and Related Structures.

Current edition approved Aug. 1, 2019. Published November 2019. Originally approved in 1998. Last previous edition approved in 2011 as D6251/D6251M – 11. DOI: 10.1520/D6251_D6251M-19.

mendations issued by the World Trade Organization Technical Barriers to Trade (TBT) Committee.

2. Referenced Documents

2.1 ASTM Standards:²

D996 Terminology of Packaging and Distribution Environments

D1990 Practice for Establishing Allowable Properties for Visually-Graded Dimension Lumber from In-Grade Tests of Full-Size Specimens

D3951 Practice for Commercial Packaging

D3953 Specification for Strapping, Flat Steel and Seals

D4169 Practice for Performance Testing of Shipping Containers and Systems

D4727/D4727M Specification for Corrugated and Solid Fiberboard Sheet Stock (Container Grade) and Cut Shapes

D6199 Practice for Quality of Wood Members of Containers and Pallets

D6253 Practice for Treatment and/or Marking of Wood Packaging Materials

F1667 Specification for Driven Fasteners: Nails, Spikes, and Staples

IEEE/ASTM SI 10 Standard for Use of the International System of Units (SI): The Modern Metric System

2.2 Federal Specifications:³

A-A-58078 Plastic Board (For Packaging Applications)

FF-F-133 Fasteners, Wood Joint, Corrugated – (Saw Edge)

2.3 Code of Federal Regulations:⁴

CFR Parts 107-180 Title 49, Hazardous Materials Regulations

2.4 APA—The Engineered Wood Association:⁵

PRP-108 Performance Standards and Policies for Structural-Use Panels

PS 1-07 Structural Plywood

² For referenced ASTM standards, visit the ASTM website, www.astm.org, or contact ASTM Customer Service at service@astm.org. For *Annual Book of ASTM Standards* volume information, refer to the standard's Document Summary page on the ASTM website.

³ Available from ASSIST Quicksearch, <https://quicksearch.dla.mil/qsSearch.aspx>.

⁴ Available from U.S. Government Printing Office Superintendent of Documents, 732 N. Capitol St., NW, Mail Stop: SDE, Washington, DC 20401, <https://www.ecfr.gov/cgi-bin/ECFR?page=browse>.

⁵ Available from APA—The Engineered Wood Association, 7011 South 19th Street, Tacoma, WA 98466, <http://www.apawood.org>.

*A Summary of Changes section appears at the end of this standard

- 2.5 American Wood Protection Association (AWPA):⁶
P36 Standard for Copper Naphthenate (CuN)
P37 Standard for Oxine Copper (Copper-8-Quinolinolate) (Cu8)
- 2.6 Military Standard:⁷
MIL-DTL-2427 Detail Specification Box, Ammunition Packing: Wood, Nailed
- 2.7 Hardwood Plywood and Veneer Association:⁸
ANSI/HPVA HP-1-2004 American National Standard for Hardwood and Decorative Plywood
- 2.8 National Institute of Standards and Technology (NIST):⁹
PS 2-04 Performance Standard for Wood-Based Structural-Use Panels⁵
- 2.9 American Lumber Standards Committee (ALSC):¹⁰
PS 20-05 American Softwood Lumber Standard
- 2.10 National Hardwood Lumber Association (NHLA):¹¹
Rules for the Measurement and Inspection of Hardwood and Cypress
- 2.11 National Motor Freight Traffic Association:¹²
National Motor Freight Classification
- 2.12 International Standards for Phytosanitary Measures (IPPC):¹³
ISPM No. 15 Guidelines for Regulating Wood Packaging Material in International Trade

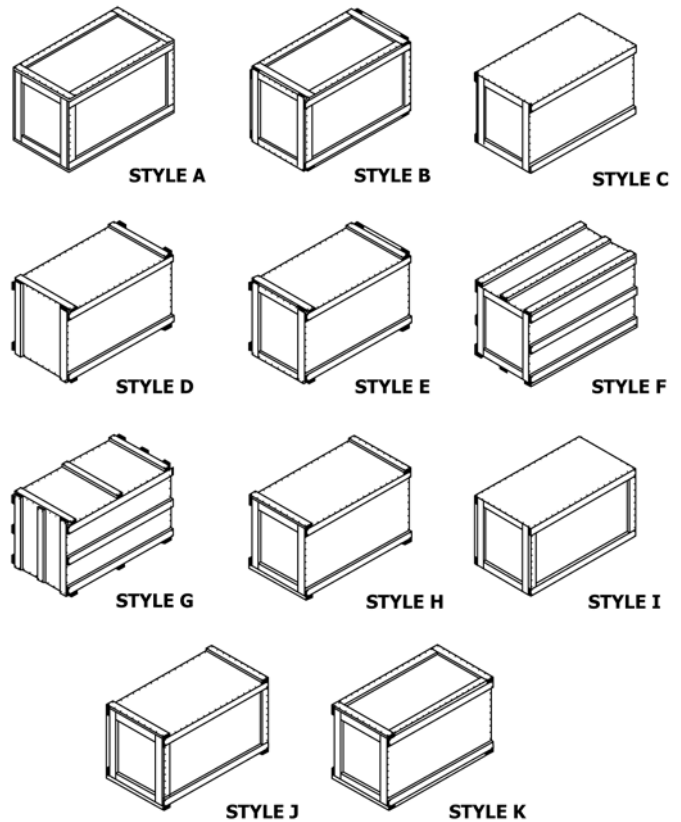

FIG. 1 Styles of Cleated Panel Boxes

3. Terminology

3.1 General definitions for packaging and distribution environments are found in Terminology **D996**.

4. Classification

- 4.1 *Type* (see 4.3):
 - 4.1.1 *Type I*—Corrugated plastic.
 - 4.1.2 *Type II*—Corrugated and solid fiberboard.
 - 4.1.3 *Type III*—Plywood.
 - 4.1.4 *Type IV*—Oriented strand board (OSB) (only Style A, B, I, and J).
- 4.2 *Class*:
 - 4.2.1 *Class 1*—Domestic (see 10.1.1).
 - 4.2.2 *Class 2*—Overseas (see 10.1.2).
- 4.3 *Style* (see Fig. 1 and 10.1):
 - 4.3.1 *Style A*—Standard box corner (see Fig. 2).
 - 4.3.2 *Style A1*—Type I and II, Style A, modified with skids and when specified (see 5.1.3) unnailed top panel closure (see 4.6 and Fig. 3).

⁶ Available from American Wood Protection Association (AWPA), P.O. Box 361784, Birmingham, AL 35236-1784, <http://www.awpa.org>.

⁷ Available from ASSIST Quicksearch, <https://quicksearch.dla.mil/qsSearch.aspx>.

⁸ Available from Hardwood Plywood and Veneer Association (HPVA), P.O. Box 2789, Reston, VA 22090-0789, <http://www.hpva.org>.

⁹ Available from National Institute of Standards and Technology (NIST), 100 Bureau Dr., Stop 1070, Gaithersburg, MD 20899-1070, <http://www.nist.gov>.

¹⁰ Available from American Lumber Standards Committee (ALSC), P.O. Box 210, Germantown, MD 20875-0210, <http://www.alsc.org>.

¹¹ Available from National Hardwood Lumber Association (NHLA), 6830 Raleigh LaGrange Rd., Memphis, TN 38134, <http://www.natllhardwood.org>.

¹² Available from National Motor Freight Traffic Association (NMFTA), 1001 N. Fairfax St., Suite 600, Alexandria, VA 22314, <http://www.nmfta.org>.

¹³ Available from the International Plant Protection Convention, www.ippc.int.

4.3.3 *Style B*—Interlocking three-way corners (see Fig. 4).
 4.3.4 *Style C through K*—Limited only to Type II, Class 1 (see 5.1.2 and Fig. 1).

4.3.5 *Style A, B, I, and J*—Type III limited only to these styles (see 5.1.2 and Fig. 1)

4.4 *Water-Repellent Wood Preservative* (see 5.1.13):

4.4.1 *Treatment A*—Without water-repellent wood preservative.

4.4.2 *Treatment B*—With water-repellent wood preservative.

4.5 *Load Type* (see 5.1.19 and 10.2):

4.5.1 *Type 1*—Easy.

4.5.2 *Type 2*—Average.

4.5.3 *Type 3*—Difficult.

4.6 *Unnailed Top Panel Closure Option*—When specified (see 4.3.2 and 5.1.3), Type I and II, Style A1, or Type III and Type IV, Style A or B shall have the top panel modified (see 7.1.8) and closed with flat steel strapping as specified in the Supplemental Requirements. Securing the top panel to the box with other than flat steel strapping shall be prohibited.

4.7 *Part Number*—If required, a specification part number for boxes described in this specification can be formulated (see S3.3).

5. Ordering Information

5.1 Purchasers shall select the preferred permitted options and include the following information in procurement documents:

5.1.1 Specification title, number, and date.

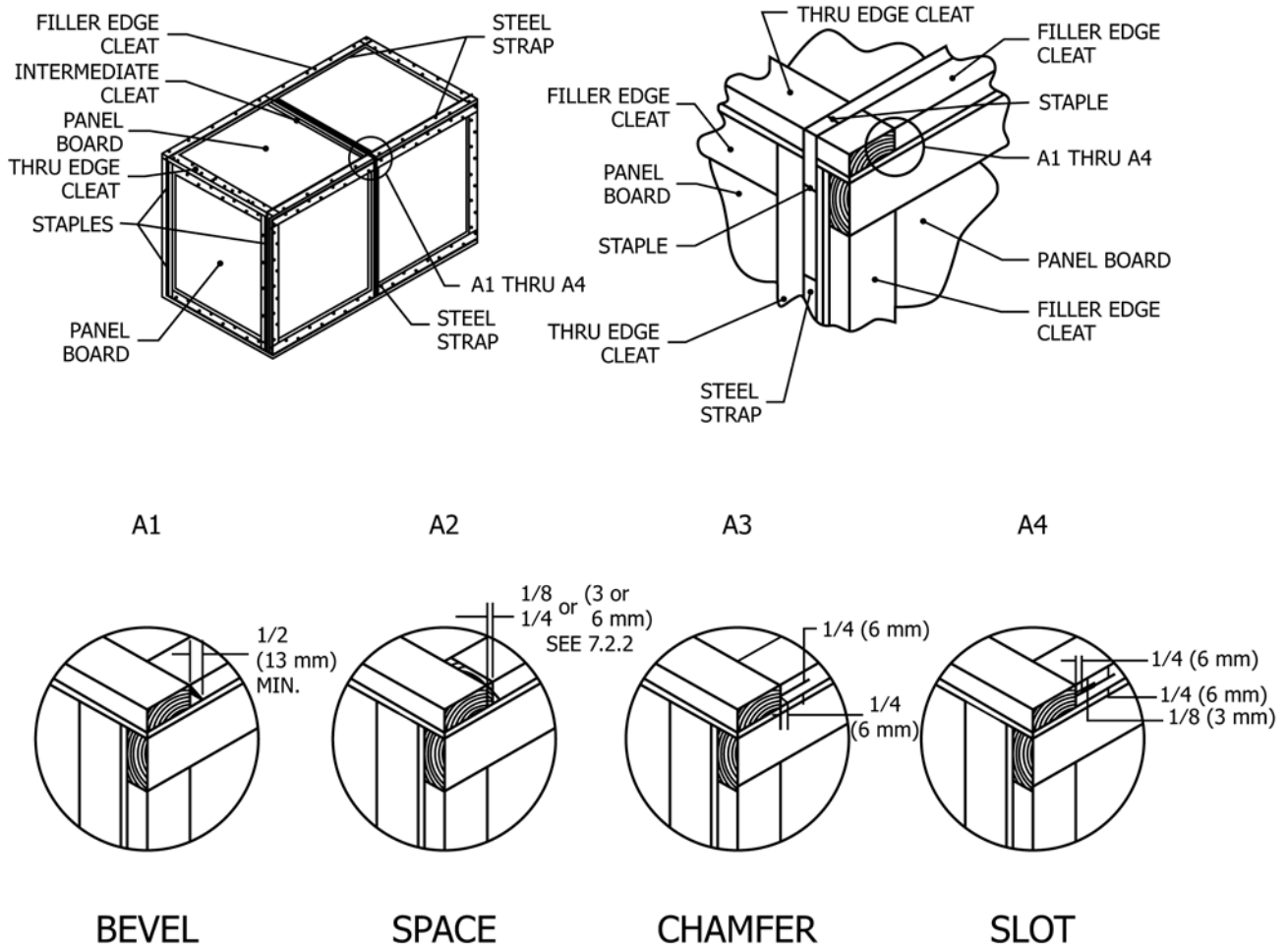

A – FILLER AND INTERMEDIATE CLEAT ENDS AND RELATION TO THROUGH EDGE CLEATS

FIG. 2 Style A Box

5.1.2 Box type, class, style, preservative treatment, load type, and closure required (see 4.1 – 4.6, and 6.5).

5.1.3 When Type I and II, Style A1; or Type III and IV, Style A or B, unnailed top panel closure is required (see 4.3, 4.6, and 7.1.8).

5.1.4 Contents weight (see Tables 1-8).

5.1.5 Cleat lumber quality classification required (see 6.3).

5.1.6 Lumber quality used for skid fabrication (see 6.3).

5.1.7 Intermediate cleat requirements for Type III and IV, Class 1 and Class 2, Style I and J (see 7.2.2).

5.1.8 When skids are not required for boxes with gross weights of 200 lb [91 kg] or 100 lb [45 kg] with dimensions of 48 by 24 in. [1219 by 610 mm] or more (see 7.7.2).

5.1.9 When beveled skids are required (see 7.7.2).

5.1.10 When four-way entry skids are required and when nominal 4 by 4-in. [90 by 90-mm] built-up skids are required (see 7.7.3).

5.1.11 Whether container manufacturer's identification is required (see 7.8).

5.1.11.1 Whether modifications to container manufacturer's identification are required (see 7.8.6).

5.1.12 Box dimensions (inside measurements, panel to panel) specified in order of length by width by depth (see 7.5).

5.1.13 When water-repellent wood preservative treatment is required for plywood and cleats (see 4.4 and 6.5).

5.1.14 Whether boxes are to be shipped assembled or knocked-down (see 9.1).

5.1.15 When Class 1 boxes require external strapping (see S1.1).

5.1.15.1 When Class 2 boxes do not require strapping (see S1.1).

5.1.16 When seal joint specimens are required prior to strapping operations (see S3.1.1).

5.1.17 Whether other construction methods or techniques are acceptable and permitted (see 1.3).

5.1.17.1 Whether proof is required that other construction methods or techniques are acceptable (see 1.3).